

DMP670
DMS365
DMS369



DMP/DMS Series

INSTALLATION/OWNER'S MANUAL

Marine Speakers



Safety Precautions

- To prevent injury and damage to the unit, please read and follow the instructions in this manual.
- If you feel unsure about installing this system yourself, have it installed by a qualified audio technician.
- Before installation, disconnect the battery negative (-) terminal to prevent damage to the unit, fire and/or possible injury.

Preparation/Installation

Please read entire manual before installation.

Before You Start

- Disconnect negative battery terminal. Consult a qualified technician for instructions.
- Use extreme caution when drilling holes to avoid damaging fuel lines, hydraulic lines or existing wiring.
- If additional wiring is required, we recommend that you run all wires prior to mounting your speaker in place.
- Use the highest quality connectors for a reliable installation and to minimize signal and power loss.
- Use caution before you drill or cut! Be careful not to cut or drill into gas tanks, fuel lines, hydraulic lines, vacuum lines or electrical wiring.
- Avoid running wires over, near, or through sharp edged surfaces. We suggest you also use rubber grommets to protect any wires routed through metal.

Mounting and Installation

- Determine where the speakers will be mounted. Ensure an area large enough for the speaker to mount evenly. Be sure the mounting location is deep enough for the speaker to fit.
- Using an appropriate tool, cut the appropriate size mounting hole (see specifications).
- Remove grille from speaker by inserting the release key into the locking tab slots located around the outside of the grille. Gently apply pressure towards the center of the grille to release the locking tabs.
- Use the speaker as a template to mark the locations for the mounting screws. Drill the mounting screw holes with a 1/8" pilot bit. Route speaker wires and connect to speakers, observing speaker polarity.
- Install speaker into opening using supplied hardware and test for correct operation.
- Align the speaker grille locking tabs and snap grille into place.

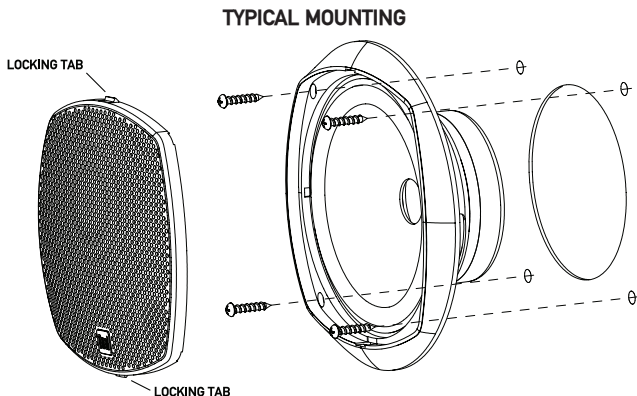

Specifications

DMP670

- Overall Diameter: **7.13" (181mm)**
- Mounting Depth: **2.13" (54mm)**
- Mounting Height: **.87" (22mm)**
- Cut out Diameter: **5.13" (130mm)**
- Frequency Response: **45Hz-15kHz**
- Sensitivity: **88dB @1W/1M**
- Impedance: **4 ohm**
- RMS Power: **20 Watts**
- Peak Power: **100 Watts**

DMS365

- Overall Diameter: **7.13" (181mm)**
- Mounting Depth: **2.40" (61mm)**
- Mounting Height: **1.02" (26mm)**
- Cut out Diameter: **5.13" (130mm)**
- Frequency Response: **45Hz-17kHz**
- Sensitivity: **88dB @1W/1M**
- Impedance: **4 ohm**
- RMS Power: **30 Watts**
- Peak Power: **120 Watts**

DMS369

- Overall Diameter: **10.55" (268mm) x 7.87" (200mm)**
- Mounting Depth: **3.47" (88mm)**
- Mounting Height: **1.34" (34mm)**
- Cut out Diameter: **8.47" (215mm) x 5.71" (145mm)**
- Frequency Response: **42Hz-17kHz**
- Sensitivity: **89dB @1W/1M**
- Impedance: **4 ohm**
- RMS Power: **50 Watts**
- Peak Power: **200 Watts**

Design and specifications subject to change without notice.

Limited One Year Warranty

This warranty gives you specific legal rights. You may also have other rights which vary from state to state.

Dual Electronics Corp. warrants this product to the original purchaser to be free from defects in material and workmanship for a period of one year from the date of the original purchase.

Dual Electronics Corp. agrees, at our option, during the warranty period, to repair any defect in material or workmanship or to furnish an equal new, renewed or comparable product (whichever is deemed necessary) in exchange without charges, subject to verification of the defect or malfunction and proof of the date of purchase. Subsequent replacement products are warranted for the balance of the original warranty period.

Who is covered? This warranty is extended to the original retail purchaser for products purchased and used in the U.S.A.

What is covered? This warranty covers all defects in material and workmanship in this product. The following are not covered:

installation/removal costs, damage resulting from accident, misuse, abuse, neglect, product modification, improper installation, incorrect line voltage, unauthorized repair or failure to follow instructions supplied with the product, or damage occurring during return shipment of the product.

What to do?

1. Before you call for service, check the troubleshooting guide in your owner's manual. A slight adjustment of any custom controls or connections discussed in your instruction booklet may save you a service call.
2. If you require service during the warranty period, you must carefully pack the product (preferably in the original package) and ship it by prepaid transportation with a copy of the original receipt from the retailer to an authorized service center.
3. Please describe your problem in writing and include your name, a USA return shipping address (P.O. Box not acceptable), and a daytime phone number with your shipment.
4. For more information and for the location of the nearest authorized service center please contact us by one of the following methods:

- Call us toll-free at 1-866-382-5476
- E-mail us at cs@dualav.com

Exclusion of Certain Damages: This warranty is exclusive and in lieu of any and all other warranties, expressed or implied, including without limitation the implied warranties of merchantability and fitness for a particular purpose and any obligation, liability, right, claim or remedy in contract or tort, whether or not arising from the company's negligence, actual or imputed. No person or representative is authorized to assume for the company any other liability in connection with the sale of this product. In no event shall the company be liable for indirect, incidental or consequential damages.

Dual Electronics Corp.
Toll Free: 1-866-382-5476

www.dualav.com
©2013 Dual Electronics Corp.
NSA1012-V01