

# BUCAM200

## Rear View Camera

### What's Inside The Box

1. Product Sheet
2. BUCAM200 Camera w/ Adjustable Mount
3. Power Cable w/ Fuse, Video Cable, 2 Mounting Screws and Foam Rubber Mounting Pad.

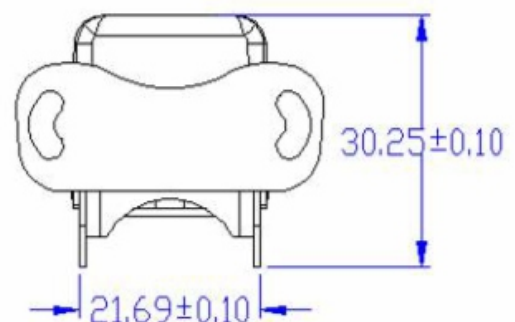
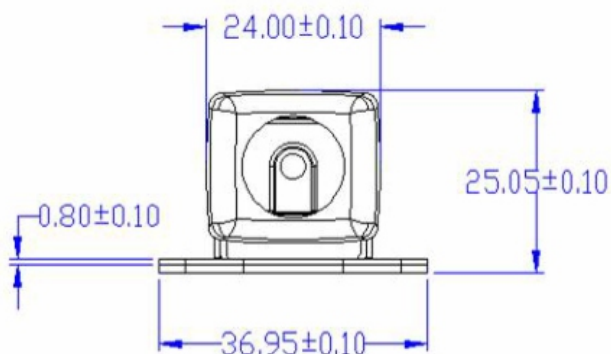

**Measurements are in millimeters (mm)**

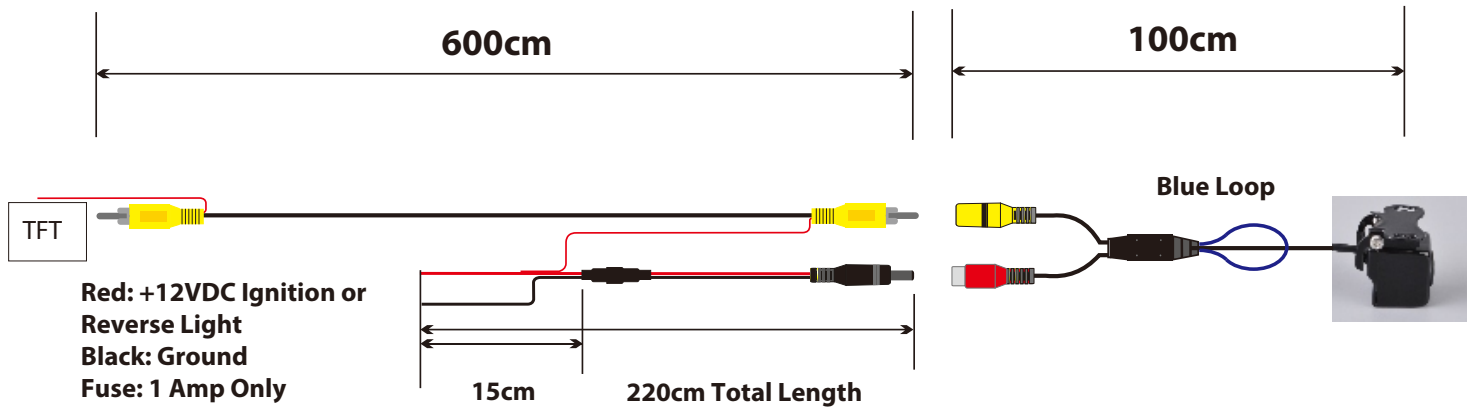

**Note: Video cable has a built-in power wire (2 red wires on either end) for ease of installation. Only 1 cable has to be routed during installation.**

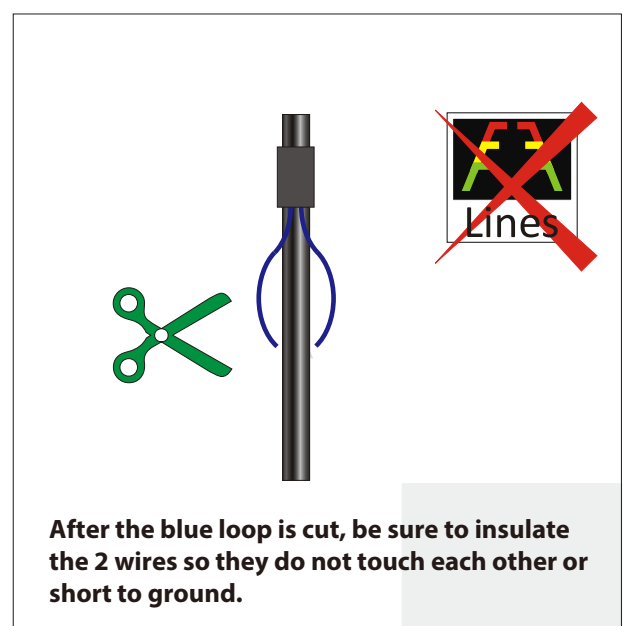
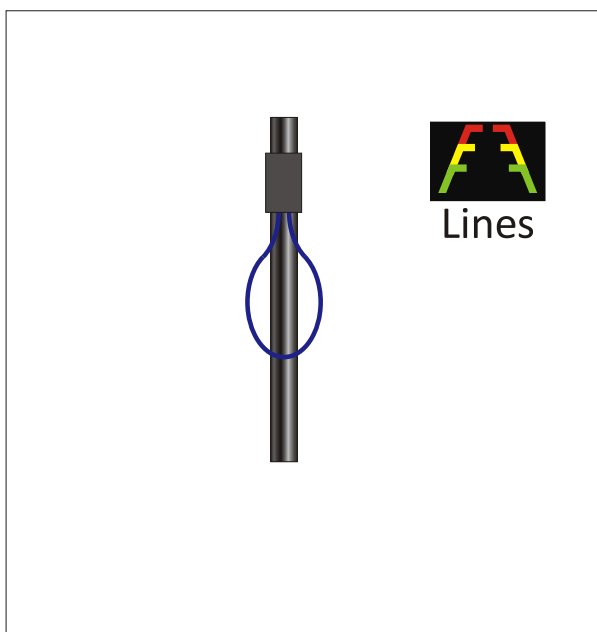

## Camera Specifications

Image Sensor: CMOS, PC7070

Power: 12VDC, Negative Ground

Power Consumption: <1 Watt

Effective Pixels: 640x480

Video Format NTSC

Lux: <0.5

White Balance: Auto

Viewing Angle: 170 Degrees

IP Rating: IP67

Operating Temperature: -15F ~ 160F

Camera Body: Zinc Alloy

## Limited One Year Warranty

This warranty gives you specific legal rights. You may also have other rights which vary from state to state.

Dual Electronics Corp. warrants this product to the original purchaser to be free from defects in material and workmanship for a period of 1(one) year from the date of the original purchase.

Dual Electronics Corp. agrees, at our option, during the warranty period, to repair any defect in material or workmanship or to furnish an equal new, renewed or comparable product (whichever is deemed necessary) in exchange without charges, subject to verification of the defect or malfunction and proof of the date of purchase. Subsequent replacement products are warranted for the balance of the original warranty period.

**Who is covered?** This warranty is extended to the original retail purchaser for products purchased from an authorized Jensen / Dual or Axxera dealer and used in the U.S.A.

**What is covered?** This warranty covers all defects in material and workmanship in this product. The following are not covered: software, installation/removal costs, damage resulting from accident, misuse, abuse, neglect, product modification, improper installation, incorrect line voltage, unauthorized repair or failure to follow instructions supplied with the product, or damage occurring during return shipment of the product. Specific license conditions and copyright notices for the software can be found via [www.dualav.com](http://www.dualav.com).

## What to do?

1. Before you call for service, check the troubleshooting guide in your owner's manual. A slight adjustment of any custom controls may save you a service call.
2. If you require service during the warranty period, you must carefully pack the product (preferably in the original package) and ship it by prepaid transportation with a copy of the original receipt from the retailer to an authorized service center.
3. Please describe your problem in writing and include your name, a return UPS shipping address (P.O. Box not acceptable), and a daytime phone number with your shipment.
4. For more information and for the location of the nearest authorized service center please contact us by one of the following methods:
  - Call us toll-free at 1-866-382-5476
  - E-mail us at [cs@dualav.com](mailto:cs@dualav.com)

**Exclusion of Certain Damages:** This warranty is exclusive and in lieu of any and all other warranties, expressed or implied, including without limitation the implied warranties of merchantability and fitness for a particular purpose and any obligation, liability, right, claim or remedy in contract or tort, whether or not arising from the company's negligence, actual or imputed. No person or representative is authorized to assume, for the company, any other liability in connection with the sale of this product. In no event shall the company be liable for indirect, incidental or consequential damages.