



## DV715B

### QUICK START GUIDE

Multimedia DVD Receiver with Bluetooth featuring a 7" digital TFT LCD

This Quick Start Guide gives you the basics to start using your DV715B. Please visit [www.dualav.com](http://www.dualav.com)

to download a complete owner's manual or call customer service at 1-866-382-5476 (Monday-Friday, 9AM-5PM EST).



Customer Service Toll Free: 1-866-382-5476

## Installation

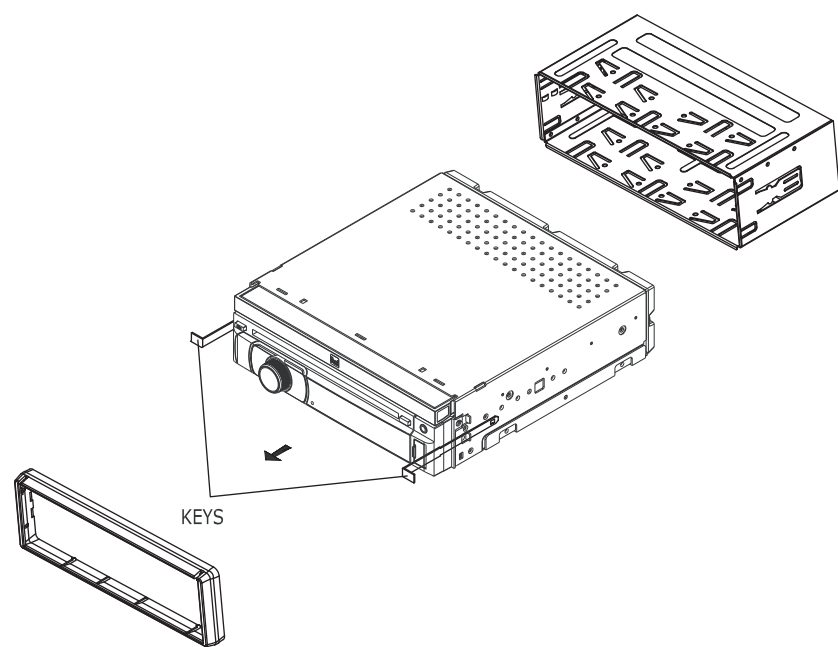

TYPICAL FRONT-LOAD DIN MOUNTING METHOD

### Copyright and Trademark Notes

This product incorporates copyright protection technology that is protected by method claims of certain U.S. patents and other intellectual property rights owned by Macrovision Corporation and other rights owners. Use of this copyright protection technology must be authorized by Macrovision Corporation, and is intended for home and other limited viewing uses only unless otherwise authorized by Macrovision Corporation. Reverse engineering or disassembly is prohibited. DVD Logo is a trademark of DVD Format/Logo Licensing Corporation registered in the U.S., Japan and other countries. SD Logo is a trademark of SD-3C, LLC. iPod and iPhone are trademarks of Apple Inc., registered in the U.S. and other countries. Dual Electronics Corporation is not affiliated with Apple, Inc. Other trademarks and trade names are those of their respective owners.

## Wiring Diagram - Inputs/Outputs

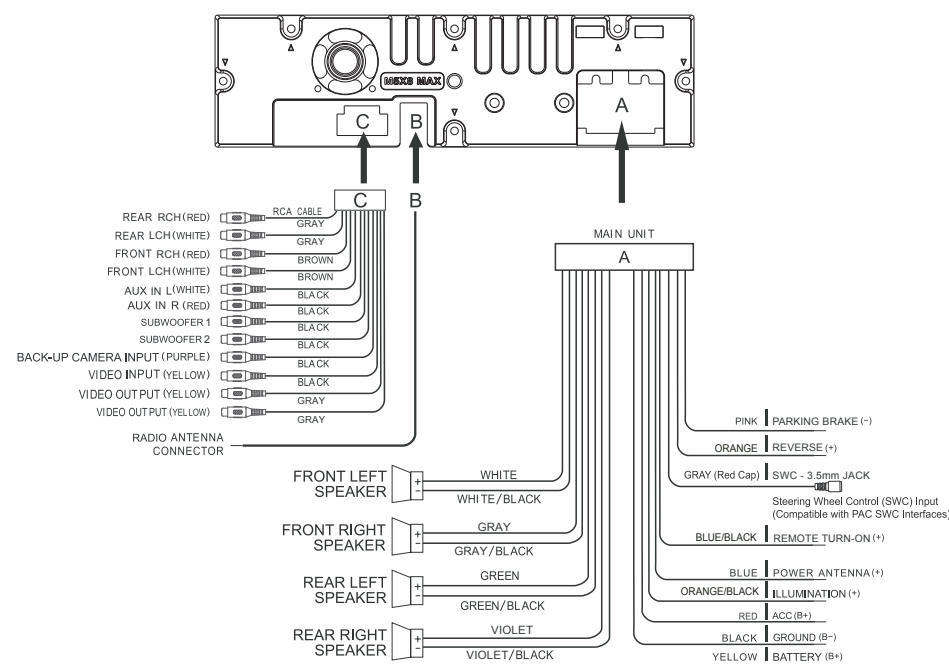

## Control Locations



- |                                |                     |  |
|--------------------------------|---------------------|--|
| 1. Eject - Press to eject disc | 6. VOL Up/Down/Talk | 11. Press- Mode Change<br>Press and hold -- Voice Activation |
| 2. AUX IN                      | 7. Mute/End call    |  |
| 3. USB Slot                    | 8. Band             | 12. Tune/Track Up  |
| 4. Mic                         | 9. Open/Power       | 13. Reset  |
| 5. Tune/Track Down             | 10. Release         | 14. microSD  |

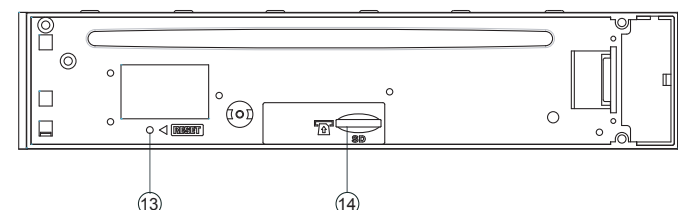

## Main Menu

In the Menu mode, press the desired icon to enter the corresponding mode: Radio, Disc, microSD Card, Rear AV In, USB, BT Phone, BT Audio, Front AUX In.

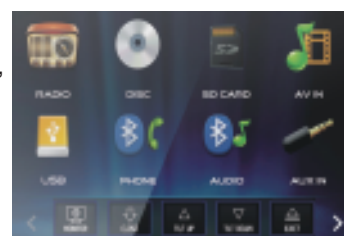

## General Operation

Press the function icons to select the setup menu.

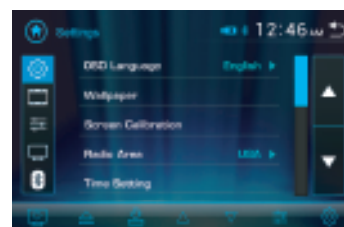

## Tuner Operation

Select the Tuner icon from the Main Menu screen or press MODE until Tuner is selected.

1. Current Mode Indicator
2. Information Display
3. Tune Up
4. Preset
5. AS/PS
6. Stereo
7. Local/DX
8. Band
9. Tune Down



## DVD Operation

Insert a DVD in the disc slot for playback.

1. Repeat
2. Track Down
3. Play/Pause
4. Track Up
5. Random
6. Audio
7. Setup
8. Monitor On/Off
9. Audio Setting
10. Subtitle
11. Zoom
12. Screen Setup

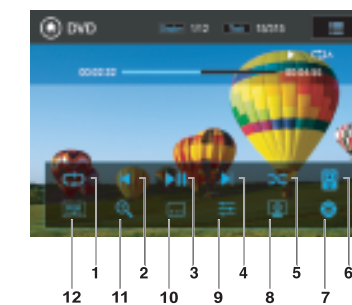

## CD / USB Operations

Insert a CD in the disc slot, and the unit will read the disc.

USB operation will work the same way when you insert the USB device into unit's USB port.

1. Previous Menu
2. Repeat
3. Random
4. Setting
5. File List
6. Audio
7. Track Up
8. Tilt Down
9. Tilt Up
10. Play/Pause
11. Close
12. Eject
13. Track Down
14. Monitor On/Off

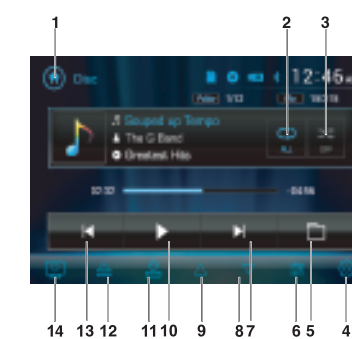

## Audio Operation

Press Sound Effect icon in the Settings menu to select EQ Presets, 7-Band Tone Control, Surround Sound, Fader and Balance controls.

1. EQ Settings
2. Surround Mode Settings
3. Fader/Balance



## Voice Activation Operation

Bluetooth should be paired between your smartphone and the receiver. Press and hold the voice activation button (V), and the receiver will switch into Bluetooth mode. This will activate Siri® or Google Assistant™ on your smartphone. You will need to manually switch back to the previous or desired mode once this operation is terminated.

## Bluetooth Operation

### Bluetooth Microphone

The microphone is built-in to the receiver.

### Pairing and Connecting

Before using Bluetooth functions, you must pair your mobile phone to the DV715B unit. The device name is "DV715B", The Bluetooth passcode "0000".

To ensure the best reception for pairing and re-connection, please make sure the mobile phone battery is fully charged before you begin.

- Try to perform pairing within a few minutes of the mobile phone being turned on.
- Once the unit has been paired with the mobile phone, the unit's model number, "DV715B", will be displayed on the mobile phone.
- To achieve the best performance, always keep the mobile phone within 10 feet (3 meters) of the unit.
- Always keep a clear path between the mobile phone and the unit. Never place a metal object or any other obstacle between the mobile phone and the unit.
- Some mobile phones may have a "Power Saving Mode" option. PLEASE DO NOT use the power saving mode with the DV715B.
- Before accepting or making a call, make sure your mobile phone's "Bluetooth function" is turned on.
- To ensure the best conversation quality/performance, stay within 3 feet (1 meter) of the unit's microphone when talking.
- To manually disconnect the mobile phone from the unit, touch the "Hang-Up" icon on the Bluetooth user interface (next to the mobile phone name) and the Bluetooth device will be "disconnected", but still paired.

## Dialing a Number

Press **Keypad** to display keypad and dial a number.

## Making and Ending a Call

Press **Call** to connect a call, and press **End Call** to end a call.

## Transferring Audio

Press **Transfer** to transfer audio between the head unit and mobile phone.

## Streaming Audio

Press **Play/Pause** to play or pause the music.

Press **Previous** to skip to the previous track.

Press **Next** to advance to the next track.



## Phone Book

Press **Phone Book** to download the phone numbers or access the call history info.

## Safety Notice

Upon installation of this Monitor/DVD/Bluetooth ("unit") into a vehicle, the driver of the vehicle must not operate this unit by watching movies, videos, or playing video games while driving. Many states prohibit cell phone operation while the vehicle is in operation. Check <https://www.ghsa.org/> if you reside in a jurisdiction which has enacted such a law, this unit must be operated in accordance of your local jurisdiction. This unit includes a parking brake lock-out safety feature which prohibits the unit's video function(s) from operating if the vehicle is not in "Park" and/or the parking brake is not fully engaged. When installing this unit, the installer fully understands and agrees to correctly connect the parking brake detect wire ("Pink Lead") to the vehicles parking brake electronic mechanism in order to fully enable the parking brake lock-out feature. DO NOT ground the parking brake detect wire to a metal portion of the vehicle. Once the parking brake lock-out feature is installed, the owner/user must not attempt to disrupt/neutralize the parking brake lock-out feature by (a) partially engaging the parking brake and/or (b) purchasing/using any device or unit designed to circumvent the safety lock-out function. When operating this unit, keep the unit's volume level low enough so that the vehicle's occupants can hear traffic-related sounds such as police and emergency vehicles. Failure to follow these instructions could lead to driver distraction, which could result in serious injury, or death.

## One-Year Limited Warranty

This warranty gives you specific legal rights. You may also have other rights which vary from state to state. Dual Electronics Corp. warrants this product to the original purchaser to be free from defects in material and workmanship for a period of one year from the date of the original purchase. Dual Electronics Corp. agrees, at our option, during the warranty period, to repair any defect in material or workmanship or to furnish an equal new, renewed or comparable product (whichever is deemed necessary) in exchange without charges, subject to verification of the defect or malfunction and proof of the date of purchase. Subsequent replacement products are warranted for the balance of the original warranty period. Who is covered? This warranty is extended to the original retail purchaser for products purchased from an authorized Dual dealer and used in the U.S.A. What is covered? This warranty covers all defects in material and workmanship in this product. The following are not covered: software, installation/removal costs, damage resulting from accident, misuse, abuse, neglect, product modification, improper installation, incorrect line voltage, unauthorized repair or failure to follow instructions supplied with the product, or damage occurring during return shipment of the product. Specific license conditions and copyright notices for the software can be found via [www.dualav.com](http://www.dualav.com).

### What to do?

1. Before you call for service, check the troubleshooting guide in your owner's manual. A slight adjustment of any custom controls may save you a service call.
  2. If you require service during the warranty period, you must carefully pack the product (preferably in the original package) and ship it by prepaid transportation with a copy of the original receipt from the retailer to an authorized service center.
  3. Please describe your problem in writing and include your name, a return UPS shipping address (P.O. Box not acceptable), and a daytime phone number with your shipment.
  4. For more information and for the location of the nearest authorized service center please contact us by one of the following methods:
    - Call us toll-free at 1-866-382-5476 (Monday-Friday, 9:00 a.m. to 5:00 p.m. EST)
    - E-mail us at [cs@dualav.com](mailto:cs@dualav.com)
- Exclusion of Certain Damages: This warranty is exclusive and in lieu of any and all other warranties, expressed or implied, including without limitation the implied warranties of merchantability and fitness for a particular purpose and any obligation, liability, right, claim or remedy in contract or tort, whether or not arising from the company's negligence, actual or imputed. No person or representative is authorized to assume for the company any other liability in connection with the sale of this product. In no event shall the company be liable for indirect, incidental or consequential damages.

## FCC Compliance

This device complies with Part 15 of the FCC Rules. Operation is subject to the following two conditions: (1) this device may not cause harmful interference, and (2) this device must accept any interference received, including interference that may cause undesired operation. **Warning:** Changes or modifications to this unit not expressly approved by the party responsible for compliance could void the user's authority to operate the equipment. **Note:** This equipment has been tested and found to comply with the limits for a Class B digital device, pursuant to Part 15 of the FCC Rules. These limits are designed to provide reasonable protection against harmful interference in a residential installation. This equipment generates, uses and can radiate radio frequency energy and, if not installed and used in accordance with the instructions, may cause harmful interference to radio communications. However, there is no guarantee that interference will not occur in a particular installation. If this equipment does cause harmful interference to radio or television reception, which can be determined by turning the equipment off and on, the user is encouraged to try to correct the interference by one or more of the following measures:

- Reorient or relocate the receiving antenna.
- Increase the separation between the equipment and receiver.
- Connect the equipment into an outlet on a circuit different from that to which the receiver is connected.
- Consult the dealer or an experienced radio/TV technician for help.