



DMA5600

INSTALLATION / OWNER'S MANUAL

5-Channel Class D Marine Amplifier



INSTALLATION

Preparation

Please read entire manual before installation. Due to the technical nature of amplifiers, it is highly recommended that your amplifier is installed by a professional installer or an authorized dealer.

Before You Start

- Disconnect negative battery terminal (consult qualified technician for instructions).
- Avoid installing the amplifier where it will be subject to high temperatures (such as from direct sunlight) or subject to dust, dirt or excessive vibration.
- Use extreme caution when drilling holes to avoid damaging fuel lines or existing vehicle wiring.
- All amplifier installations require power, signal and speaker wires (not included).
- An amplifier installation kit (sold separately) is highly recommended to facilitate the installation. Consult your dealer for recommendations.

Mounting Location

- Choose a mounting location for the amplifier.
- The amplifier can be mounted horizontal (recommended) or vertical. For optimum performance, make sure to provide at least 1" of space around all sides. Do not mount the amplifier under carpets or where airflow is restricted.
- The optimum mounting location varies. Remember to test all amplifier functions before completing the final mounting procedure.

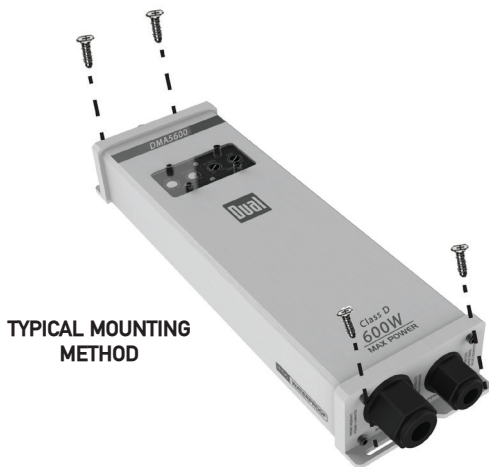

INSTALLATION

Connection Descriptions

Note: Be sure to follow specific instructions included with your amplifier installation kit (not included with this amplifier). The information below should be used as a general guideline only.

Power Wire (+12V)

- Disconnect negative battery terminal before proceeding. Consult a qualified technician for instructions if you are unsure.
- Plan wire routing before cutting any wires to length. Begin by routing the power +12V wire from the battery to the amplifier location. Use a grommet when running wires through the firewall or metal openings. Avoid running the power wire near existing vehicle wiring to prevent induced noise from entering the audio system.
- Use extreme caution when drilling holes to avoid damaging fuel lines or existing vehicle wiring.
- The +12V wire **MUST** be fused within 18" of the battery for protection of the vehicle's electrical system.

Ground Wire (GND)

- The amplifier ground wire should be as short as possible (no more than 36" or 1 meter). Choose a clean unpainted section of metal or the vehicle chassis when attaching the ground connection. Be sure to clean the area of any dirt or grease.

Speaker Wires

- Choose adequate gauge speaker wire depending on your exact amplifier/speaker combination. Be sure to observe polarity when connecting.
- Do not ground any speaker wires or connect any speaker wires together.

Input Signal

- The amplifier's input signal connects to the head unit's low level (RCA) outputs.

CAUTION

- Keep low level inputs away from any power wires to avoid engine noise.
- Never run any wires underneath or outside the vehicle.

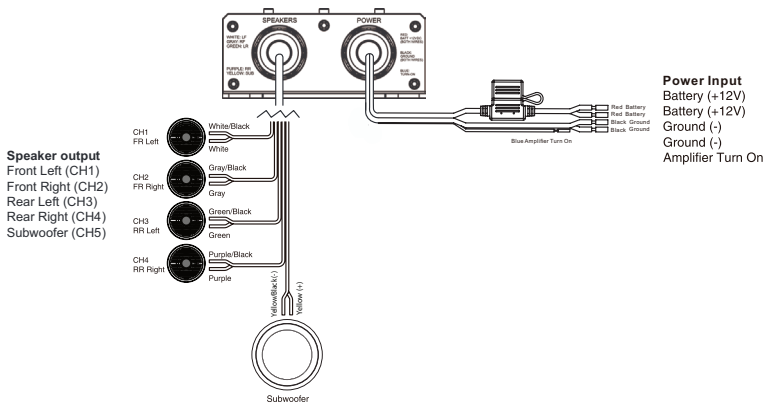

INSTALLATION

Audio Inputs and Controls All Channels

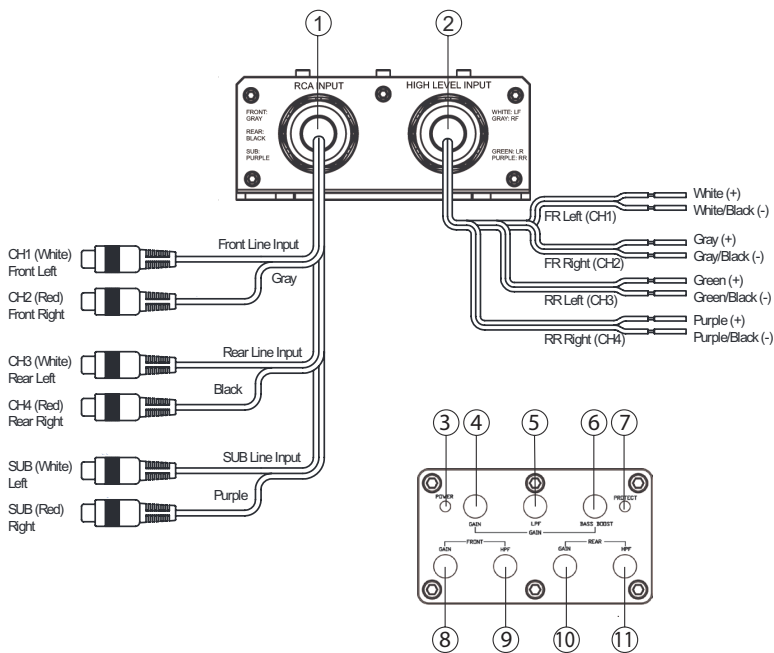

- 1 Low-Level Inputs (RCA)
- 2 High-Level Inputs (Speaker Wire)
- 3 Power Indicator Light
- 4 Gain Control
- 5 Low-Pass Filter
- 6 Bass Boost Control
- 7 Protect Indicator Light
- 8 Front Gain Control
- 9 Front High-Pass Filter
- 10 Rear Gain Control
- 11 Rear High-Pass Filter

INSTALLATION

Audio Outputs All Channels

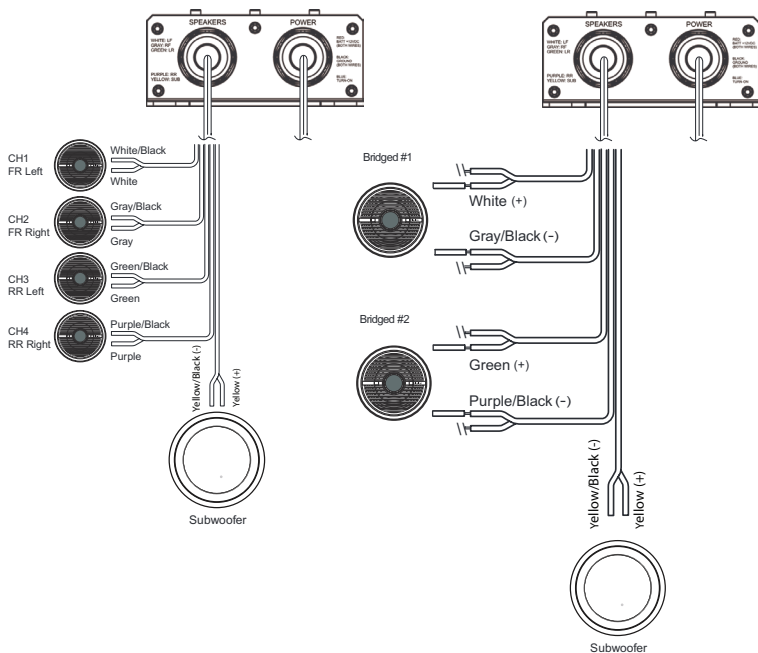

Configuration/Setup

Gain	<p>After installation, complete the following steps to set gain control and perform final system checks.</p> <ol style="list-style-type: none">1. Turn the gain control all the way counterclockwise.2. Turn the ignition switch on.3. Turn the source unit on.4. Set all tone or equalization controls to flat positions and turn loudness off.5. Play music content and set the volume control to 75% of full level. <p>Note: If the system uses an equalizer, set all frequency controls to the flat position.</p> <ol style="list-style-type: none">6. Slowly increase the gain control. Stop when you hear a slight audio distortion.
Crossover	<p>The DMA5600 is equipped with high-pass crossovers on channels 1-4 and low-pass crossover on channel 5. Use the Frequency control to select the frequency.</p>
Bass Boost	<p>Set the bass boost control to off. After listening to a variety of music styles, switch the bass boost control on until you notice an increase in low bass response.</p> <p>Note: If you hear a pop caused by speaker overexertion, lower the bass boost to prevent damage to the speaker.</p>

OPERATION

Troubleshooting

Problem	Cause	Action
Unit will not turn on (no power LED indicator)	+12V wire not connected or incorrect voltage. REM wire not connected or incorrect voltage	Check connections for proper voltage (11~16VDC)
	GND wire not connected	Check connection to ground
	Fuse(s) blown	Replace fuse(s)
Unit has power - LED is blue (but no sound)	Speaker wires not connected	Check connections at speakers
	Volume turned all the way down	Increase volume level at head unit
	One or more speaker wires touching each other or touching chassis ground	Insulate all bare speaker wires from each other and chassis ground
	Speaker(s) defective or damaged	Check/replace speaker(s)
	Input signal not connected	Check high or low level inputs for proper connection
Unit blows fuse(s)	Incorrect fuse rating	Use fuse(s) with correct rating
	+12V wire touching chassis ground	Check for pinched wire
	Speaker(s) defective or damaged	Check/replace speaker(s)
Engine noise	Bad ground connection	Make sure amplifier is grounded to clean bare metal
	Signal ground loop or RFI (radio frequency interference)	Re-route RCA cables from existing high current wiring
LED illuminates red (protect mode)	One or more speaker wires touching each other or touching chassis ground	Insulate all bare speaker wires from each other and chassis ground
	Speaker(s) defective or damaged internally (shorted)	Check/replace speaker(s)
	Speaker load less than 2 ohms (stereo). Speaker load less than 4 ohms (bridged)	Adjust speaker load - amplifier will not operate at less than 4 ohms when bridged
Distorted audio output	Incorrect input signal type or input level too high	Check connections and reduce/adjust input level
Low audio output	Incorrect input signal type or input level too low	Check connections and increase/adjust input level

Features / Specifications

Power Output

- 50 Watts x 4 channels @ 4 Ohms+ 200 Watts x 1 channel (sub)
- 75 Watts x 4 Channels @ 2 Ohms+ 300 Watts x 1 channel (sub)
- 150 Watts x 2 Channels @ 4 Ohms (bridged)
- 600 Watts Peak Power Output

Fuse Rating: 40A x 2

Signal to noise ratio: > 70dB (THD < 0.5% @ 4 Ω , 14.4V)

Frequency response: 35Hz-30kHz (channel 1-4); 15-250Hz (channel 5/sub)

Channel separation: \leq 48dB

Frequency response: 35Hz – 30kHz full range

Line level input sensitivity: 200mV to 8 Volts

Speaker level input sensitivity: 600mV to 20 Volts

Input impedance: 22k Ω

Amplifier dimensions: 8.89" x 3.09" x 1.58" (226 mm x 78.5mm x 40mm)

- Class D
- Total Harmonic Distortion (THD): \leq 1%
- 4 Layer Conformal Coated PCB Assembly
- Variable Bass Boost @50Hz (0-12dB)
- MOSFET Power Supply
- 12dB/Oct. Low/High Pass Electronic Crossover
- Variable High-Pass Crossover: 35Hz-30kHz (RF/RR)
- Variable Low-Pass Crossover: 35-250Hz (Sub)
- Variable Gain Controls: Front, Rear, Sub
- Turn-On/Off Muting Circuitry (Soft Mute)
- Ground Loop Isolation Input Circuit
- Corrosion Resistant Nickel Plated RCA, Power, and Speaker Connections
- RCA and High Level Speaker Inputs

Design and specifications subject to change without notice.

One-Year Limited Warranty

This warranty gives you specific legal rights. You may also have other rights which vary from state to state.

Dual Electronics Corp. warrants this product to the original purchaser to be free from defects in material and workmanship for a period of one year from the date of the original purchase.

Dual Electronics Corp. agrees, at our option, during the warranty period, to repair any defect in material or workmanship or to furnish an equal new, renewed or comparable product (whichever is deemed necessary) in exchange without charges, subject to verification of the defect or malfunction and proof of the date of purchase. Subsequent replacement products are warranted for the balance of the original warranty period.

Who is covered? This warranty is extended to the original retail purchaser for products purchased from an authorized Dual dealer and used in the U.S.A.

What is covered? This warranty covers all defects in material and workmanship in this product. The following are not covered: software, installation/removal costs, damage resulting from accident, misuse, abuse, neglect, product modification, improper installation, incorrect line voltage, unauthorized repair or failure to follow instructions supplied with the product, or damage occurring during return shipment of the product. Specific license conditions and copyright notices for the software can be found via www.dualav.com.

What to do?

1. Before you call for service, check the troubleshooting guide in your owner's manual. A slight adjustment of any custom controls may save you a service call.
2. If you require service during the warranty period, you must carefully pack the product (preferably in the original package) and ship it by prepaid transportation with a copy of the original receipt from the retailer to an authorized service center.
3. Please describe your problem in writing and include your name, a return UPS shipping address (P.O. Box not acceptable), and a daytime phone number with your shipment.
4. For more information and for the location of the nearest authorized service center please contact us by one of the following methods:
 - Call us toll-free at 1-866-382-5476
 - E-mail us at cs@dualav.com

Exclusion of Certain Damages: This warranty is exclusive and in lieu of any and all other warranties, expressed or implied, including without limitation the implied warranties of merchantability and fitness for a particular purpose and any obligation, liability, right, claim or remedy in contract or tort, whether or not arising from the company's negligence, actual or imputed. No person or representative is authorized to assume for the company any other liability in connection with the sale of this product. In no event shall the company be liable for indirect, incidental or consequential damages.



Details and specifications mentioned in this document may be updated and subject to change without notice.
To access the latest document, please check the product website.

Dual Electronics Corp.
Toll Free: 1-866-382-5476
Monday-Friday, 9AM-5PM, EST

www.dualav.com
©2016 Dual Electronics Corp.
NSA1116-V01