

SG3/SG4/SG5

INSTALLATION/OWNER'S MANUAL
Universal Marine Splash Guard





Preparation

Protect your marine head unit from damage and the harsh marine environment with the SG3/SG4/SG5 splash guard. This marine grade cover fits most single DIN size head units and will protect against splashes and debris.

Before You Start

- Disconnect negative battery terminal. Consult a qualified marine technician or service manual for instructions.
- Due to differences in head units, it is recommended to temporarily mount head unit in splash guard before installation to ensure splashguard cover will close properly.
- Use extreme caution when drilling holes to avoid damaging fuel lines or existing wiring.

Cutout Dimensions

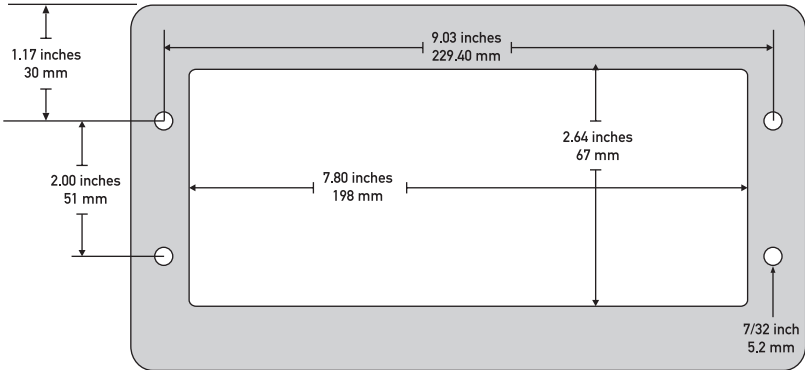

Opening and Closing the Splash Guard

- Press the release button on top to open the cover and access the head unit.
- To close, fold the cover up and press until it clicks into place.

Release Button



Mounting

Mounting

- Open splashguard and detach side covers by pulling outward from the inside of side cover.
- Insert supplied mounting bolts through washers and into mounting holes as shown below.
- Place gasket between back side of splash guard and mounting surface and secure the splash guard in place with supplied nuts.
- Install head unit into splash guard opening. This may vary depending on head unit manufacturer and installation instructions. Refer to head unit owner's manual for details.
- Reattach side covers by aligning them and pushing firmly into place.

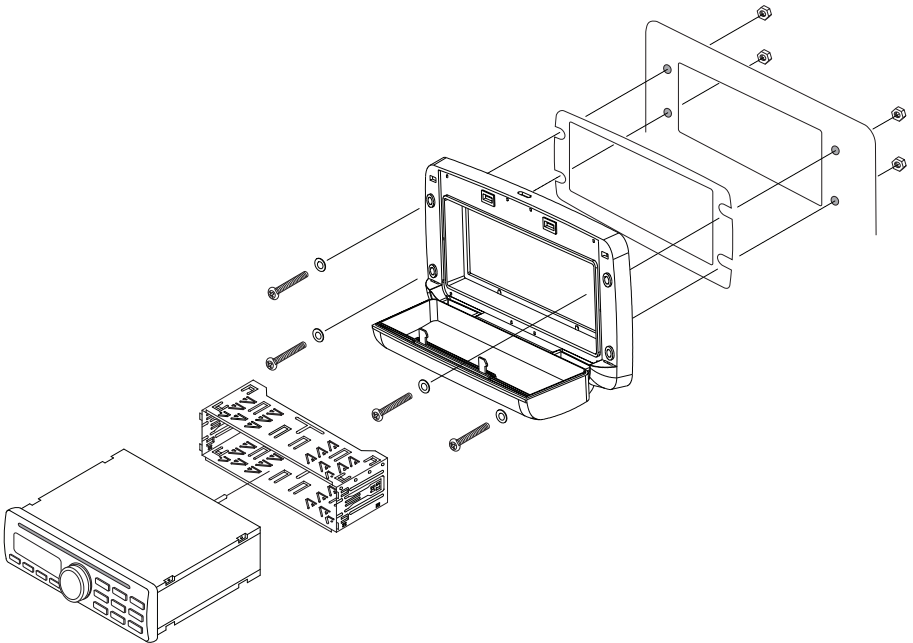

TYPICAL MOUNTING
***Head Unit not included.**



Limited One Year Warranty

This warranty gives you specific legal rights. You may also have other rights which vary from state to state.

Dual Electronics Corp. warrants this product to the original purchaser to be free from defects in material and workmanship for a period of one year from the date of the original purchase.

Dual Electronics Corp. agrees, at our option, during the warranty period, to repair any defect in material or workmanship or to furnish an equal new, renewed or comparable product (whichever is deemed necessary) in exchange without charges, subject to verification of the defect or malfunction and proof of the date of purchase. Subsequent replacement products are warranted for the balance of the original warranty period.

Who is covered? This warranty is extended to the original retail purchaser for products purchased from an authorized Dual dealer and used in the U.S.A.

What is covered? This warranty covers all defects in material and workmanship in this product. The following are not covered: software, installation/removal costs, damage resulting from accident, misuse, abuse, neglect, product modification, improper installation, incorrect line voltage, unauthorized repair or failure to follow instructions supplied with the product, or damage occurring during return shipment of the product. Specific license conditions and copyright notices for the software can be found via www.dualav.com.

What to do?

1. Before you call for service, check the troubleshooting guide in your owner's manual. A slight adjustment of any custom controls may save you a service call.
2. If you require service during the warranty period, you must carefully pack the product (preferably in the original package) and ship it by prepaid transportation with a copy of the original receipt from the retailer to an authorized service center.
3. Please describe your problem in writing and include your name, a return UPS shipping address (P.O. Box not acceptable), and a daytime phone number with your shipment.
4. For more information and for the location of the nearest authorized service center please contact us by one of the following methods:
 - Call us toll-free at 1-866-382-5476
 - E-mail us at cs@dualav.com

Exclusion of Certain Damages: This warranty is exclusive and in lieu of any and all other warranties, expressed or implied, including without limitation the implied warranties of merchantability and fitness for a particular purpose and any obligation, liability, right, claim or remedy in contract or tort, whether or not arising from the company's negligence, actual or imputed. No person or representative is authorized to assume for the company any other liability in connection with the sale of this product. In no event shall the company be liable for indirect, incidental or consequential damages.

Dual Electronics Corp.
Toll Free: 1-866-382-5476
Monday - Friday, 9AM - 5PM EST

www.dualav.com
©2014 Dual Electronics Corp. All rights reserved.