



## DV637MB

### QUICK START GUIDE

Multimedia DVD Receiver with 2-Way DualMirror™ Technology and Bluetooth featuring a 6.2" digital TFT LCD

This Quick Start Guide gives you the basics to start using your DV637MB. Please visit [www.dualav.com/support/manuals.php](http://www.dualav.com/support/manuals.php) to download a complete owner's manual or call customer service at 1-866-382-5476 (Monday-Friday, 9AM-5PM EST), or email at [cs@dualav.com](mailto:cs@dualav.com)



Customer Service Toll Free: 1-866-382-5476

#### Safety Notes:

The DVD video display of the in-dash unit will not operate while the vehicle is moving. This is a safety feature to prevent driver distraction. In-dash DVD video functions will only operate when vehicle is in Park and the parking brake is engaged. It is illegal in most states for the driver to view video while the vehicle is in motion.

## Installation

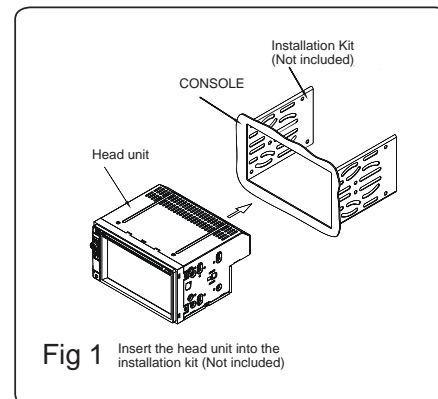

Fig 1 Insert the head unit into the installation kit (Not included)

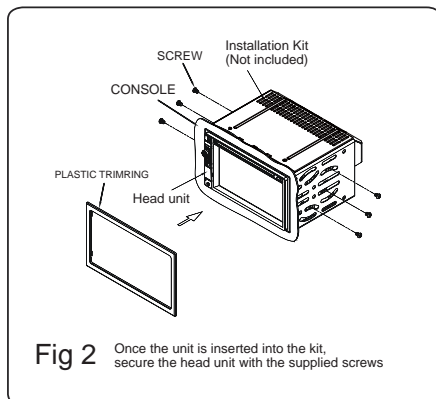

Fig 2 Once the unit is inserted into the kit, secure the head unit with the supplied screws

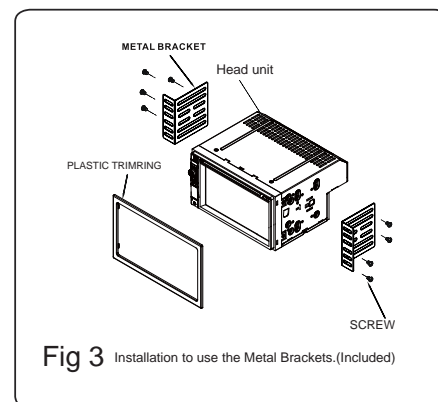

Fig 3 Installation to use the Metal Brackets (Included)

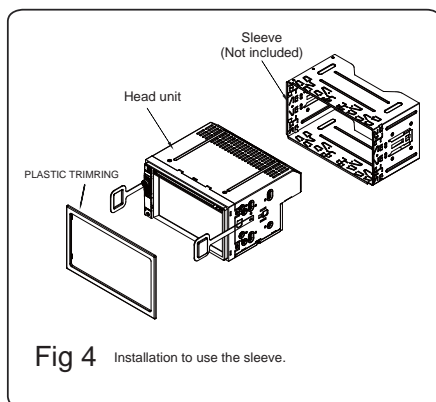
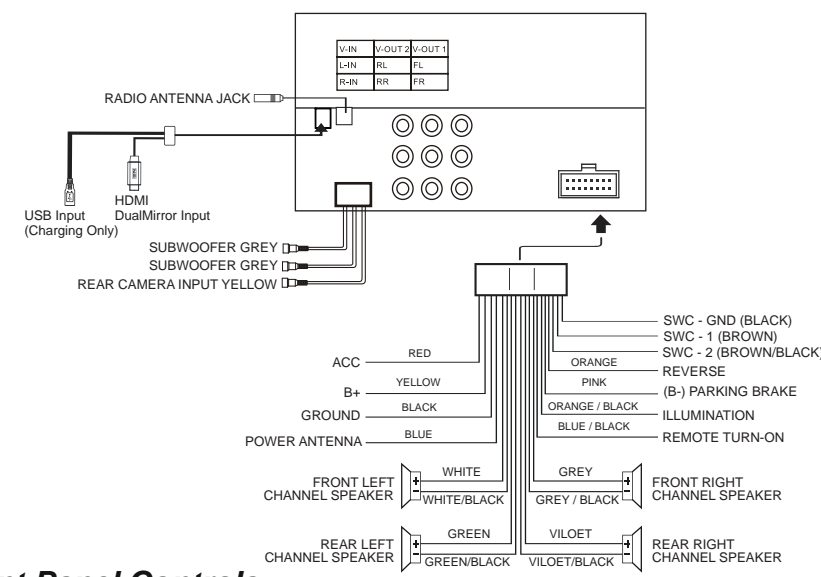

Fig 4 Installation to use the sleeve.

#### Copyright and Trademark Notes

This product incorporates copyright protection technology that is protected by method claims of certain U.S. patents and other intellectual property rights owned by Macrovision Corporation and other rights owners. Use of this copyright protection technology must be authorized by Macrovision Corporation, and is intended for home and other limited viewing uses only unless otherwise authorized by Macrovision Corporation. Reverse engineering or disassembly is prohibited. DVD Logo is a trademark of DVD Format/Logo Licensing Corporation registered in the U.S., Japan and other countries. SD Logo is a trademark of SD-3C, LLC. iPod and iPhone are trademarks of Apple Inc., registered in the U.S. and other countries. Dual Electronics Corporation is not affiliated with Apple, Inc. Other trademarks and trade names are those of their respective owners.

## Wiring Diagram



## Front Panel Controls



- |                          |         |          |           |
|--------------------------|---------|----------|-----------|
| 1. Power/Mode            | 4. Mute | 7. USB   | 9. Aux In |
| 2. Play/Pause/CH1-6      | 5. Mic  | 8. Reset | 10. Eject |
| 3. Select/Volume Up/Down | 6. IR   |          |           |

## Remote Controls

- |  |                                   |
|--|-----------------------------------|
| 1. Power & Mode                                    | 14. EQ(Equalizer)                 |
| 2. Talk  | Loud(ness)                        |
| 3. Adjust angle(optional)                          | 15. Goto & *                      |
| 4. Setup   | 16. Mute                          |
| 5. Subtitle & Local/Dx(Distant)                    | 17. END & Reject                  |
| 6. Tune/Previous Track                             | 18. Clock                         |
| 7. Band  | 19. SEL(Select)                   |
| 8. Title/PBC                                       | 20. Tune/Next Track               |
| (Push Button Configuration)                        | 21. OK                            |
| &AS/PS(Automatic Memory storing & Preset Scanning) | 22. Forward                       |
| 9. Back  | 23. Stop                          |
| 10. Volume Up/Down                                 | 24. Play/Pause                    |
| 11. Menu & Subwoofer                               | 25. 9/TA                          |
| 12. Angle & Zoom                                   | (Traffic Announcement)            |
| 13. Audio & MO(Mono) /ST(Stereo)                   | 26. +10/#                         |
|  | 27. 0/AF(Alterative Frequencies)  |
|  | 28. CH+/CH-(TV Tuner models only) |

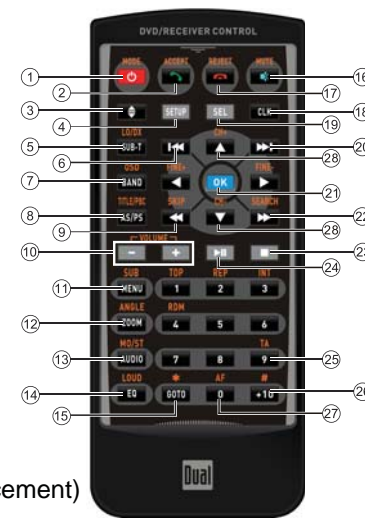

## Main Menu

In the Main Menu screen, press the desired icon to enter each of the following settings : Radio, Disc (CD/DVD), USB, Bluetooth Phone, Bluetooth Music DualMirror, Rear-view Camera, Aux In, AV In, Setup



## Setup Operations

In the Main Menu, press Setup icon to enter the general settings for the device

- General(Animation, Key Beep, Disc, Radio,...)
- Time(Adjust Time and Time format)
- Video(Adjust Color, Brightness, Contrast, Tint)
- Language(Select Language)
- RGB Illumination(Backlight and Buttons color)
- Calibration(TFT Calibration)



## Radio Operations

Press MODE button on the Control Panel until Tuner is selected

- Home
- Information Display
- Tune Up
- Preset Station Display
- Next Menu
- BAND
- AS/PS(Automatic Memory Storing & Preset Scanning)
- Audio Setup
- Mute
- Previous Menu
- Tune Down
- Local/Dx(Distant)
- PTY(Program type)
- TA(Traffic Announcement)
- AF(Alterative Frequencies)



## DVD Operations

Insert a DVD in the disc slot for DVD playback(please see 'Safety Notes' on the front page of this guide)

- Mute
- Previous Track
- Play/Pause
- Next Track
- Back
- Forward
- Next Menu
- Repeat Play
- Random Play
- Talk
- TA(Traffic Announcement)
- AF(Alterative Frequencies)
- Previous Menu



## DISC Operations

Inserting the MP3 CD into the disc slot will make the unit automatically read the CD.

- Previous Menu
- Mute
- Audio Setup
- Back
- Forward
- Next Menu



## Audio Settings

Audio EQ Presets  
USER -> JAZZ -> CLASSIC -> POP  
ROCK -> BEAT -> FLAT  
USER PRESET

6 EQ Band frequencies are adjustable from the ASP settings. ASP menu adjust the Bass/Mid/Treb center frequencies. Each band adjusts the center frequency average(Low/Mid/High). Bass/Mid/Treb Q Value adjust the frequency width, wide to narrow. Loudness center frequency(Flat, 400, 800, 2400) Subwoofer center frequency(Flat, 80, 120, 160)



## FADER/BALANCE

FAD (F10 to R10): Fader adjusts the front-to-rear audio strength  
BAL (L10 to R10): Balance adjusts the left-to-right audio strength

## SUB/LOUD

SUB:Adjusts the subwoofer volume levels.

LOUD(Off/Low/High):Loudness feature provides better overall sound at low volume levels by increasing low and high frequencies

## Bluetooth Operations

### Bluetooth Microphone

The microphone is built-in to the receiver

### Pairing and Connecting

Before using a Bluetooth device with this unit, the device must be paired and connected. The Bluetooth signal of the unit will broadcast when the power is on. Complete the pairing sequence from your Bluetooth device. The Dual unit will be displayed as "Dual BT". When prompted, enter the passcode "0000". On your device. Once paired, the Bluetooth device should automatically connect this unit whenever the unit is in range.

### Dialing a Number

Press [Keypad] to display keypad and dial a number.

### Making and Ending a Call

Press [Call] to make a call, and press [End Call] to end a call.

### Accessing Recent Call List

Press [Recent] to view the Dialed  
Press [Received] to view the Received  
Press [Missed] to view the Missed

### Transferring Audio

Press [Transfer] to transfer audio between the head unit and mobile phone.

### Streaming Audio

Press [Stream] to enter the music control menu.  
Press [Play] to play or pause the music.  
Press [Previous] to skip to the previous track.  
Press [Next] to advance to the next track.



## 2-Way DualMirror™ Operation

See insert for DualMirror operation.

### Note:

Operating system updates from Apple and Android may cause issues with your receiver not to function properly. This can usually be fixed by doing a software /firmware update to the receiver itself. To see if your receiver has the latest firmware, contact customer service at 1-866-382-5476 to see if your radio needs an update.



## Steering Wheel Control(SWC) Operation

Steering Wheel Control Programming  
See insert for SWC Programming operation



## One-Year Limited Warranty

This warranty gives you specific legal rights. You may also have other rights which vary from state to state. Dual Electronics Corp. warrants this product to the original purchaser to be free from defects in material and workmanship for a period of one year from the date of the original purchase. Dual Electronics Corp. agrees, at our option, during the warranty period, to repair any defect in material or workmanship or to furnish an equal new, renewed or comparable product (whichever is deemed necessary) in exchange without charges, subject to verification of the defect or malfunction and proof of the date of purchase. Subsequent replacement products are warranted for the balance of the original warranty period. Who is covered? This warranty is extended to the original retail purchaser for products purchased from an authorized Dual dealer and used in the U.S.A. What is covered? This warranty covers all defects in material and workmanship in this product. The following are not covered: software, installation/removal costs, damage resulting from accident, misuse, abuse, neglect, product modification, improper installation, incorrect line voltage, unauthorized repair or failure to follow instructions supplied with the product, or damage occurring during return shipment of the product. Specific license conditions and copyright notices for the software can be found via [www.dualav.com](http://www.dualav.com).

### What to do?

- Before you call for service, check the troubleshooting guide in your owner's manual. A slight adjustment of any custom controls may save you a service call.
  - If you require service during the warranty period, you must carefully pack the product (preferably in the original package) and ship it by prepaid transportation with a copy of the original receipt from the retailer to an authorized service center.
  - Please describe your problem in writing and include your name, a return UPS shipping address (P.O. Box not acceptable), and a daytime phone number with your shipment.
  - For more information and for the location of the nearest authorized service center please contact us by one of the following methods:
    - Call us toll-free at 1-866-382-5476 (Monday-Friday, 9:00 a.m. to 5:00 p.m. EST)
    - E-mail us at [cs@dualav.com](mailto:cs@dualav.com)
- Exclusion of Certain Damages: This warranty is exclusive and in lieu of any and all other warranties, expressed or implied, including without limitation the implied warranties of merchantability and fitness for a particular purpose and any obligation, liability, right, claim or remedy in contract or tort, whether or not arising from the company's negligence, actual or imputed. No person or representative is authorized to assume for the company any other liability in connection with the sale of this product. In no event shall the company be liable for indirect, incidental or consequential damages.

## FCC Compliance

This device complies with Part 15 of the FCC Rules. Operation is subject to the following two conditions:  
(1) this device may not cause harmful interference, and  
(2) this device must accept any interference received, including interference that may cause undesired operation.  
**Warning:** Changes or modifications to this unit not expressly approved by the party responsible for compliance could void the user's authority to operate the equipment.  
**Note:** This equipment has been tested and found to comply with the limits for a Class B digital device, pursuant to Part 15 of the FCC Rules. These limits are designed to provide reasonable protection against harmful interference in a residential installation. This equipment generates, uses and can radiate radio frequency energy and, if not installed and used in accordance with the instructions, may cause harmful interference to radio communications. However, there is no guarantee that interference will not occur in a particular installation. If this equipment does cause harmful interference to radio or television reception, which can be determined by turning the equipment off and on, the user is encouraged to try to correct the interference by one or more of the following measures:  
• Reorient or relocate the receiving antenna.  
• Increase the separation between the equipment and receiver.  
• Connect the equipment into an outlet on a circuit different from that to which the receiver is connected.  
• Consult the dealer or an experienced radio/TV technician for help.