



DMS6525

INSTALLATION/OWNER'S MANUAL

6.5" 2-Way Marine Speakers





Preparation/Installation

Please read entire manual before installation.

Before You Start

- Disconnect negative battery terminal. Consult a qualified technician for instructions.
- Use extreme caution when drilling holes to avoid damaging fuel lines, hydraulic lines or existing wiring.
- If additional wiring is required, we recommend that you run all wires prior to mounting your speaker in place.
- Use the highest quality connectors for a reliable installation and to minimize signal and power loss.
- Use caution before you drill or cut! Be careful not to cut or drill into gas tanks, fuel lines, hydraulic lines, vacuum lines or electrical wiring.
- Avoid running wires over, near, or through sharp edged surfaces. We suggest you also use rubber grommets to protect any wires routed through metal.

Mounting and Installation

- Determine where the speakers will be mounted. Ensure an area large enough for the speaker to mount evenly. Be sure the mounting location is deep enough for the speaker to fit.
- Using an appropriate tool, cut a 6" diameter mounting hole (DMS6525)
- Use the speaker as a template to mark the locations for the mounting screws. Drill the mounting screw holes with a 1/8" pilot bit. Route speaker wires and connect to speakers, observing speaker polarity.
- Install speaker into opening using supplied hardware and test for correct operation.

Note: Do not connect audio outputs from your amp or receiver to the illuminITE inputs of the speakers. This will damage the LEDs and void your warranty.

Mounting

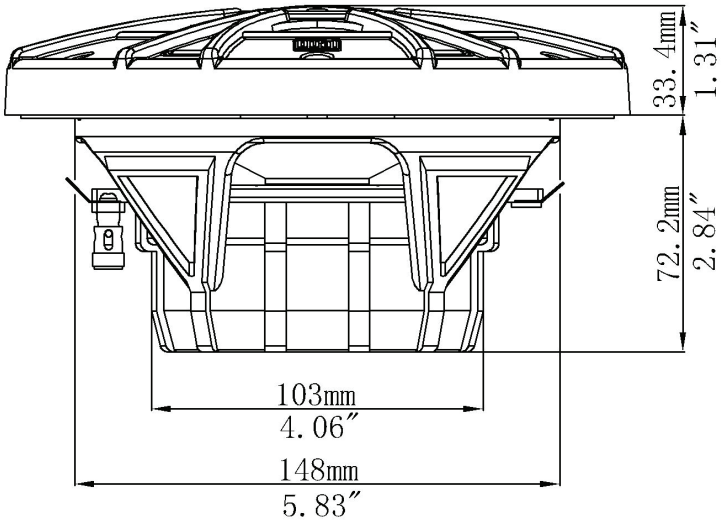

The diagrams featured above are to be used in conjunction with the specifications matrix below:

Fractional Inches	Grill Dimensions (HxWxD) or (HxDiameter)	Outside Diameter	Mounting Depth	Cut-out Diameter	Mounting Height
DMS6525	6.50"	7.51"	2.83"	6.00"	1.31"



Mounting

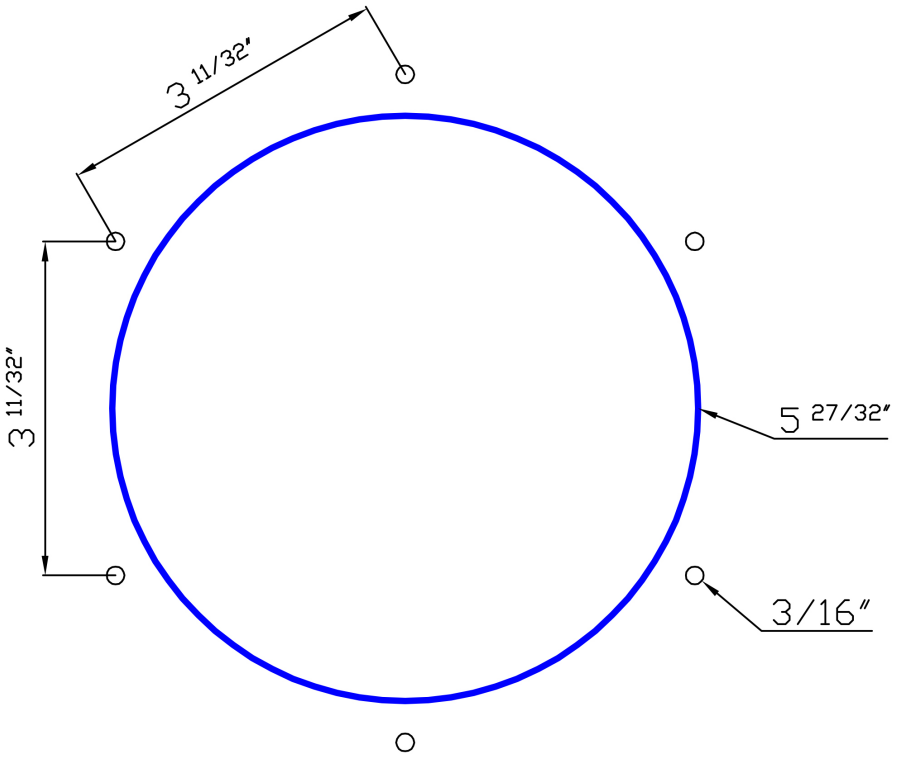



Limited One Year* Warranty

This warranty gives you specific legal rights. You may also have other rights which vary from state to state.

Dual Electronics Corp. Inc warrants this product to the original purchaser to be free from defects in material and workmanship for a period of one year from the date of the original purchase.

Dual Electronics Corp. Inc agrees, at our option, during the warranty period, to repair any defect in material or workmanship or to furnish an equal new, renewed, or comparable product (whichever is deemed necessary) in exchange without charges, subject to verification of the defect or malfunction and proof of the date of purchase. Subsequent replacement products are warranted for the balance of the original warranty period.

What is covered?

This warranty covers all defects in the material and workmanship in this product. The following are not covered: software, installation/removal costs, damage resulting from accident, misuse, abuse, neglect, product modification, improper installation, incorrect line voltage, unauthorized repair, or failure to follow instructions supplied with the product, or damage occurring during return shipment of the product. Specific license conditions and copyright notices for the software can be found via www.dualav.com.

Warranty Coverage

* Limited 1-year warranty. (Proof of purchase required)

- Extended Coverage: Extend your warranty from 1 year to 2 years when you register online at www.dualav.com. Registration must be completed within 60 days of the original purchase date to qualify for this extension.

What to do?

1. Before you call for service, check the troubleshooting guide in your owner's manual. A slight adjustment of any custom controls may save you a service call.
2. If you require service during the warranty period, you must carefully pack the product (preferably in the original package) and ship it by prepaid transportation with a copy of the original receipt from the retailer to an authorized service center.
3. Please describe your problem in writing and include your name, a return UPS shipping address (P.O. Box not acceptable), and a daytime phone number with your shipment.
4. For more information and for the location of the nearest authorized service center please contact us by one of the following methods
 - a. Call us toll-free at (866) 382-5476 (Monday-Friday, 9:00 am to 5:00 pm, EST)
 - b. E-mail us at cs@dualav.com

Exclusion of Certain Damages:

This warranty is exclusive and in lieu of any and all other warranties, expressed or implied, including without limitation the implied warranties of merchantability and fitness for a particular purpose and any obligation, liability, right, claim or remedy in contract or tort, whether or not arising from the company's negligence, actual or imputed. No person or representative is authorized to assume for the company any other liability in connection with the sale of this product. In no event shall the company be liable for indirect, incidental, or consequential damages.



DMS6525 SPECIFICATIONS

Specifications

Woofers size	6.5"
Woofers surround	Rubber
Tweeter type	PEI dome
Tweeter size	25mm
RMS Power	120W
Peak Power	480W
Sensitivity	86dB
Frequency response	60Hz - 20kHz
Impedance	4 Ohms
Basket material	UV-resistant ABS

Design and specifications subject to change without notice.



Dual Electronics Corp.
Toll Free: 1-866-382-5476
9AM-5PM EST, Monday-Friday

www.dualav.com
©2025 Dual Electronics Corp. All rights reserved.

Other trademarks and trade names are those of their respective owners.

NSA0325-V01