



# DBTMA100

---

## QUICK START GUIDE



## BOOKSHELF MICRO AMP





## What's in the box

DBTMA100  
- 1pc

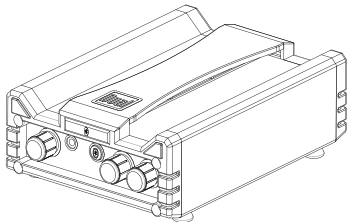

AC/DC Wall Power  
Adapter  
- 1pc

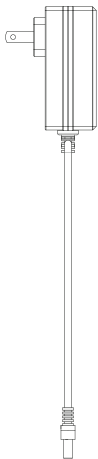

User Manual  
- 1pc



## Congratulations

On your **DBTMA100** wireless streaming micro amplifier purchase. This is compatible with most in-wall, on-wall, in-ceiling, and bookshelf speakers. Please take your time to explore all of the features and utilities we have built into this product.

We put all of our products through rigorous testing and quality control. We take great pride in presenting this product to you. For your peace of mind, we offer a one-year limited warranty against manufacturing defects and workmanship. Please refer to the warranty section of this user manual for more details.

### SUPPORT

For the latest information on all of our products, please visit:

[www.dualav.com](http://www.dualav.com)

- Call us toll-free at 1-866-382-5476
- E-mail us at [cs@dualav.com](mailto:cs@dualav.com)

All rights reserved. No part of this publication may be reproduced, distributed, or transmitted in any form or by any means, including photocopying, recording, or other electronic or mechanical methods, without the prior written permission of DUAL ELECTRONICS CORP.

All trademarks and trade names are property of their respective owners.  
Copyright © 2019 DUAL ELECTRONICS CORP.

## IMPORTANT SAFETY INFORMATION TO THE USER



*The lightning flash with arrowhead symbol within an equilateral triangle is intended to alert the user to the presence of un-isolated, dangerous voltage within the inside of the*

*device that may be of sufficient magnitude to constitute a risk of electric shock to persons*



**WARNING:** To reduce the risk of electric shock, do not remove cover or back plate as there are no user-serviceable parts inside.

Refer servicing to qualified personnel



*The exclamation point within an equilateral triangle is intended to alert the user to the presence of important operating and servicing instructions in the literature accompanying the device*



The Bluetooth® word mark and logos are registered trademarks owned by Bluetooth SIG, Inc. and any use of such marks is under license.

## IMPORTANT SAFETY PRECAUTIONS

- The **DBTMA100** does not have a weather resistant design, it should not be submerged in or underwater under any circumstances
- Set your volume control at a low setting, then slowly increase the sound until you can hear it comfortably without distortion, or ear discomfort.

**WARNING - Never leave this product in direct sunlight, overheating can cause permanent**

- Wash with a mild soap or detergent and lukewarm water using a clean sponge or a soft cloth. Rinse well with clean water.

**“Don’ts” - Very Important**

- DON'T use abrasive or highly alkaline cleaners on the main body
- DON'T ever use acetone or carbon tetrachloride

This product must not be disposed of or dumped with your other household waste. You are liable to dispose of all your electronic or electrical waste equipment by relocating over to the specified collection point for recycling of such hazardous waste. Isolated collection and proper recovery of your electronic and electrical waste equipment at the time of disposal will allow us to help conserving natural resources. Moreover, proper recycling of the electronic and electrical waste equipment will ensure safety of human health and environment. For more information about electronic and electrical waste equipment disposal, recovery, and collection points, please contact your local city center, household waste disposal service, shop from where you purchased the equipment, or manufacturer of the equipment

## INFORMATION TO THE USER

### FCC COMPLIANCE STATEMENT

This device complies with part 15 of the FCC Rules. Operation is subject to the following two conditions:

- (1) this device may not cause interference, and
- (2) this device must accept any interference, including interference that may cause undesired operation of this device.

This transmitter must not be co-located or operated in conjunction with any other antenna or transmitter. The Bluetooth antenna cannot be removed (or replaced) by user. This equipment complies with FCC/ IC radiation exposure limits set forth for an uncontrolled environment and meets the FCC radio frequency (RF) Exposure Guidelines and RSS-102 of the IC radio frequency (RF) Exposure rules. This equipment has very low levels of RF energy that it deemed to comply without maximum permissive exposure evaluation (MPE). But it is desirable that it should be installed and operated keeping the radiator at least 20 cm or more away from person's body (excluding extremities: hands, wrists, feet and ankles). Alteration or modifications carried out without appropriate authorization may invalidate the user's right to operate the equipment.

**NOTE:** This equipment has been tested and found to comply with the limits for a Class B digital device, pursuant to Part 15 of the FCC Rules. These limits are designed to provide reasonable protection against harmful interference in a residential installation. This equipment generates, uses and can radiate radio frequency energy and, if not installed and used in accordance with the instructions, may cause harmful interference to radio communications. However, there is no guarantee that interference will not occur in a particular installation. If this equipment does cause harmful interference to radio or television reception, which can be determined by turning the equipment off and on, the user is encouraged to try to correct the interference by one or more of the following measures:

- Relocate or reorient the receiving antenna.
- Increase the separation between the equipment and receiver.
- Connect the equipment into an outlet on a circuit different from that to which the receiver is connected.
- Consult the dealer or an experienced radio/TV technician for help.



#### CAUTION!!

ADJUSTMENT OR ALTERATIONS OF THIS DEVICE MAY RESULT  
IN HAZARDOUS RADIATION EXPOSURE.

## KNOW YOUR DBTMA100

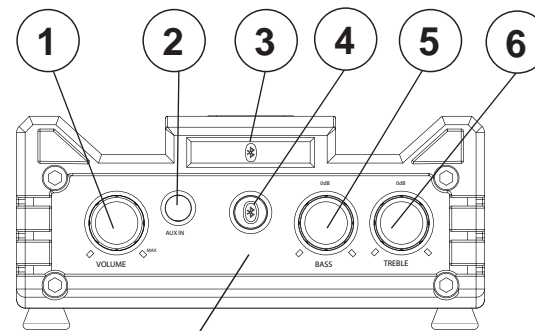

MAIN CONTROL PANEL

- 1 UNIT ON/OFF  
VOLUME LEVEL  
TOP LED ON/OFF
- 2 3.5mm AUX INPUT
- 3 BLUETOOTH STATUS LED
- 4 BLUETOOTH PAIR BUTTON
- 5 BASS LEVEL
- 6 TREBLE LEVEL

# Dual DBTMA100 - Wireless Operation

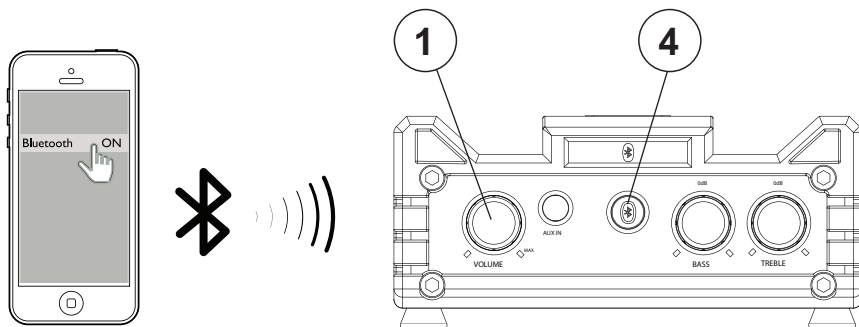

## 4 BLUETOOTH PAIRING

- Turn ON the unit - **LONG PRESS** 1 3 seconds
- **LONG PRESS** 4 3 seconds
- Turn on your Devices **BLUETOOTH** in your **SETTINGS MENU**
- Look and tap on **DBTMA100** name
- Once paired, a confirmation tone will be heard
- Streaming is now ready

### BLUETOOTH LED STATUS

BLUE LED BLINKING = BLUETOOTH NOT PAIRED

BLUE LED ON = BLUETOOTH PAIRED



Tips

To clear all previously paired BT Devices - **LONG PRESS**

4 for 10 seconds

6

QUICK START GUIDE

# DBTMA100 - Streaming Music

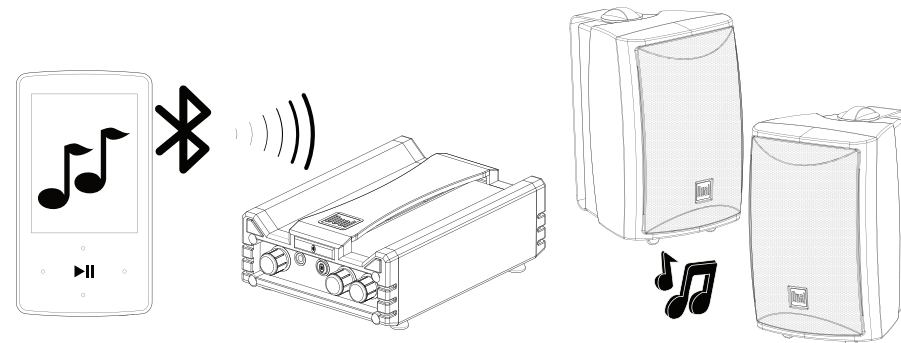

NOTE: Use you Devices touch screen to control media

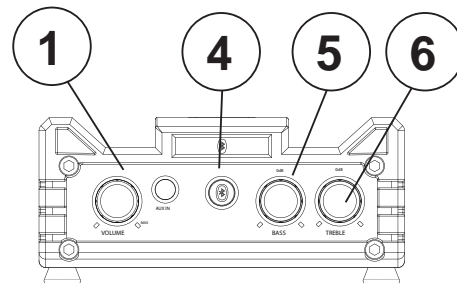

1 VOL UP/DOWN

4 PLAY/PAUSE

5 BASS LEVEL -6dB | 0 |+6dB

6 TREBLE LEVEL -6dB | 0 |+6dB

NOTE: To help conserve power, the **DBTMA100** will automatically power **OFF** after 9 minutes of non-use.



Tips

**VOLUME** level will automatically sync with most iOS

Devices. Supported Android devices may require additional setup in the Bluetooth settings menu, consult your phone manual for additional information.

7

QUICK START GUIDE

## INSTALLATION

- The **DBTMA100 wall power adapter** should be permanently connected to 120VAC wall mains

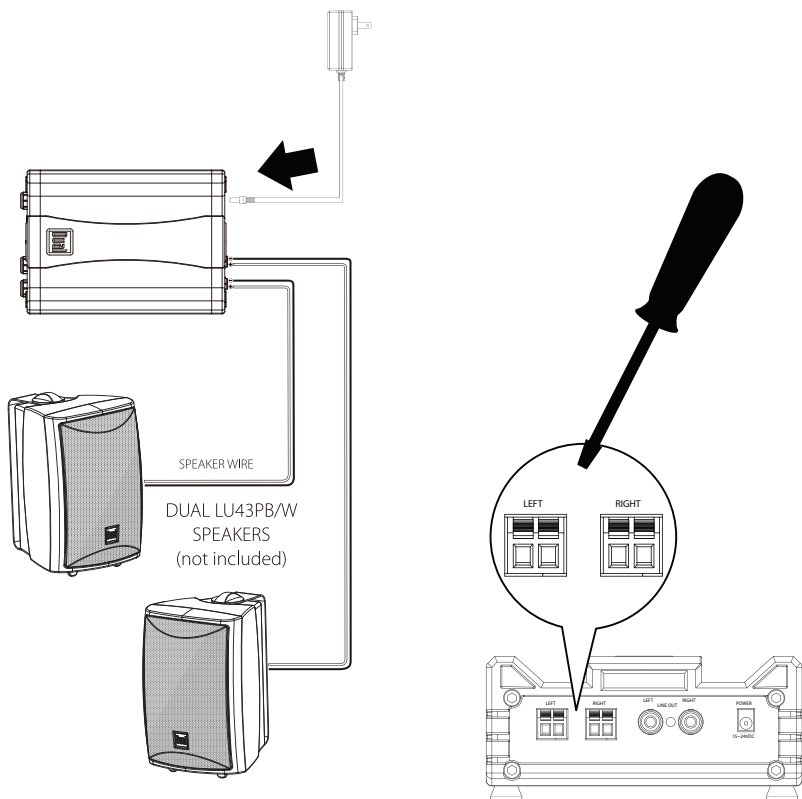

- Use a small flat blade screw driver to depress speaker spring terminals
- Strip speakers wires back approximately 1/4"
- Make sure speakers wires do not short together



Ensure speaker wire polarity is correct

## Placement

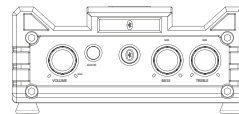

Your **DBTMA100** amplifier should be installed in a well ventilated location, such as bookshelf. It is highly recommended to be within 30 feet of your speakers.

## Hard Wiring

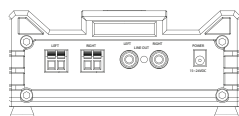

Use minimum of 16 gauge copper speaker wire (not included)

Do **NOT** wire **LEFT & RIGHT** speaker impedance below 4OHM

Do **NOT** install near, or in areas that can get wet. Double check to make sure install area does not have hazards concealed within them, such as electrical wires or plumbing. Always install in areas that are sturdy enough to support the amplifiers weight, and make sure it cannot fall or cause injury.

## Expanding the system

The **REAR RCA OUTPUTS** can be connect to another external amplifier to expand the system

## Experiment for Better Sound

You should experiment with various placements. Room acoustics can produce large apparent differences in the sound when small changes in the placement are employed.

For example, although the speaker may be located at any height above the floor, directing the tweeter toward ear level or angling the entire speaker toward the listening position often provides the most realistic imaging experience. The amount of bass perceived increases as you move a speaker closer to solid intersecting room surfaces (walls, ceiling, floor).

# Dual DBTMA100 - Specifications

## SPECIFICATIONS

### BLUETOOTH

- BT: 4.2
- BT Range: 33Ft / 10M (Class 2)
- BT Profiles: A2DP / AVRCP

### AMPLIFIER

- Frequency Response: 20~22kHz
- Channels: 2
- Bridgeable: No
- Amplifier Type: Class D
- Power Input: 15VDC / 2A (up to 24VDC / 5A allowed)
- RMS Power Output: 25W x 2 / 15VDC @ 4Ω
- MAX Power Output: 50W x 2 / 24VDC @ 4Ω
- Minimum Impedance: 4~8Ω nominal

### GENERAL

- Storage Temperature: 5°F to 160°F / -15°C to 72°C
- Operation Temperature: 14°F to 125°F / -10°C to 52°C
- Weight: 1.15lbs / 2.4Kg
- Dimensions Inches WxDxH: 5.75 x 4.25 x 1.50
- Color: Black

# DBTMA100 - Trouble Shooting

## TROUBLE SHOOTING

TROUBLE	CAUSE	SOLUTION
Unit will not turn on	AC Power is OFF	Turn wall switch ON / check breakers
	AC/DC wall adapter is unplugged	Plug AC/DC adaptor into wall
No sound is heard	Volume level is low or muted	Turn the DBTMA100 volume level up
	Device is paused or muted	Check your Devices playing / volume status
The audio quality is poor	Device volume level is too low or muted	Raise the Device volume to a higher level
The audio quality is poor after connection with a Bluetooth enabled device	The Bluetooth reception is poor	Move the Device closer to the audio system or remove any obstacle between the Device

## SUPPORT

- Call us toll-free at 1-866-382-5476
- E-mail us at [cs@dualav.com](mailto:cs@dualav.com)



### Important

The **DBTMA100** amplifier is designed to be used with multi-purpose speakers and will deliver accurate high fidelity sound in exterior or interior environments. The rugged design and construction will provide optimum durability.

This product is not meant for in-water or underwater use.

Do not attempt to remove the bottom plate from this product. There are no user-serviceable parts, removal could damage the amplifier and void the warranty.

### Warranty Coverage

You must have proof of purchase to receive warranty service. Please keep your original sales receipt and be prepared to provide this receipt in the event you require service, as your original receipt is considered the best proof of purchase and indicates the date you purchased your Dual product.

### For Your Records

Model \_\_\_\_\_

Dealer Name \_\_\_\_\_

Dealer Phone \_\_\_\_\_

Purchase Date \_\_\_\_\_

Note: You may want to keep your original sales receipt or a photo copy with this owner's manual.

## SUPPORT

- Call us toll-free at 1-866-382-5476
- E-mail us at [cs@dualav.com](mailto:cs@dualav.com)

## Limited One Year\* Warranty

This warranty gives you specific legal rights. You may also have other rights which vary from state to state.

Dual Electronics Corp. Inc warrants this product to the original purchaser to be free from defects in material and workmanship for a period of one year from the date of the original purchase.

Dual Electronics Corp. Inc agrees, at our option, during the warranty period, to repair any defect in material or workmanship or to furnish an equal new, renewed, or comparable product (whichever is deemed necessary) in exchange without charges, subject to verification of the defect or malfunction and proof of the date of purchase. Subsequent replacement products are warranted for the balance of the original warranty period.

### What is covered?

This warranty covers all defects in the material and workmanship in this product. The following are not covered: software, installation/removal costs, damage resulting from accident, misuse, abuse, neglect, product modification, improper installation, incorrect line voltage, unauthorized repair, or failure to follow instructions supplied with the product, or damage occurring during return shipment of the product. Specific license conditions and copyright notices for the software can be found via [www.dualav.com](http://www.dualav.com).

### Warranty Coverage

\* Limited 1-year warranty. (Proof of purchase required)

- Extended Coverage: Extend your warranty from 1 year to 2 years when you register online at [www.dualav.com](http://www.dualav.com). Registration must be completed within 60 days of the original purchase date to qualify for this extension.

### What to do?

1. Before you call for service, check the troubleshooting guide in your owner's manual. A slight adjustment of any custom controls may save you a service call.
2. If you require service during the warranty period, you must carefully pack the product (preferably in the original package) and ship it by prepaid transportation with a copy of the original receipt from the retailer to an authorized service center.
3. Please describe your problem in writing and include your name, a return UPS shipping address (P.O. Box not acceptable), and a daytime phone number with your shipment.
4. For more information and for the location of the nearest authorized service center please contact us by one of the following methods
  - a. Call us toll-free at (866) 382-5476 (Monday-Friday, 9:00 am to 5:00 pm, EST)
  - b. E-mail us at [cs@dualav.com](mailto:cs@dualav.com)

### Exclusion of Certain Damages:

This warranty is exclusive and in lieu of any and all other warranties, expressed or implied, including without limitation the implied warranties of merchantability and fitness for a particular purpose and any obligation, liability, right, claim or remedy in contract or tort, whether or not arising from the company's negligence, actual or imputed. No person or representative is authorized to assume for the company any other liability in connection with the sale of this product. In no event shall the company be liable for indirect, incidental, or consequential damages.

**D****CLASS-D**  
DIGITAL AMPLIFIER**100**  
WATTS**PEAK POWER**  
100 WATTS**2****2 CHANNEL**  
LEFT & RIGHT OUTPUTS

# DBTMA100

---

## QUICK START GUIDE



[www.dualav.com](http://www.dualav.com)